

Sealcoat, Crack Sealing, & Re-Striping

HOW TO APPLY FOR A PERMIT

- Complete and submit the attached permit application for Parking Lot Seal coating/Crack sealing/Striping. Applications are accepted only in person or via postal mail. Faxes and e-mails will not be accepted.
- One (1) copy of the proposal/scope of work describing the work to be done and material to be used. The value of the work to be performed shall also be included. The proposal shall include the property owner's approval.

A permit may be issued at the time of application submittal at the Village Hall for simple seal coat and re-stripe work, but any site deficiencies shall be subject to be brought up to meet current code requirements and be included as part of the permit approval.

A plan/permit review may be required by the Engineering Division, and will be completed within fifteen (15) business days. The applicant will be contacted if the application requires additional information or revisions.

The use of coal tar products is prohibited for use in the Village per Ordinance No 2018-030.

VILLAGE OF VERNON HILLS
Community Development-Engineering Division
Phone 847-367-3704 Fax 847-367-2541

PERMIT APPLICATION
PARKING LOT SEALCOATING / CRACK SEALING / RE-STRIPING

PLEASE PRINT

Vernon Hills Business/Management Name: _____

Site Address: _____

Phone No.: _____ E-Mail: _____

Applicant's Name & Business Name: _____
(If different from above)

Phone No.: _____ E-Mail: _____

Permit Application Information Required:

Cost Estimate: \$ _____

- One (1) copy of the proposal/scope of work describing the work to be done and material to be used. The value of the work to be performed shall also be included. The proposal shall include the property owner's approval.

Permit Requirements:

- All open lid storm sewer structures shall be protected to prevent debris, seal coat and pavement marking material from entering the adjacent storm sewer system and adjacent bodies of water.
- All Handicap parking spaces shall be replaced to their original locations. The relocation or elimination of these parking spaces is prohibited.
- Handicap parking striping shall be yellow in color (two coats applied).
- Handicap parking space and access aisle dimensions shall be the current requirements of the Illinois Accessibility Code and all other ADAAG and Village codes.
- All missing, non-legible and damaged signs shall be replaced throughout the entire site. Sign posts shall be straight and signs set at the proper mounting height. All missing sign posts shall be replaced to meet current Village Standards.
- Contractor shall call for a final inspection.

The use of coal tar products is prohibited within the Village (See attached memo).

I _____ have read and understand the requirements of this permit application on this date _____, 20__.

Contractor Information:

Company Name: _____

Address: _____

Phone Number: _____ E-Mail: _____

Contact Person: _____

Section 302.3.1 is created and approved to read as follows:

302.3.1—Parking Lot and Private Roadways: It is the intent of this ordinance to provide a uniform guideline of submittal requirements for permits of maintenance of existing private roadways, parking lot/loading dock resurfacing and reconstruction projects.

1. *Definition of Parking Area:* The parking area is to be defined as the pavement required for the number of parking stalls needed to accommodate the business customers and employees. The parking area covers striping, signage, lighting, drainage, and the ingress/egress areas to the business. The parking area also includes delivery and loading dock pavement.

2. *Application:* The parking area will be evaluated in unison with the property owner. After inspection, if the following items are determined to exist the owner will be notified in writing of the deficiencies.

- a. When the pavement begins to fail (i.e., potholes severe settlement or heaving, tripping hazards, asphalt failure due to sub base failure, severe cracking) as determined by the Village Engineer or the Village Code Enforcement Officer.
- b. When the pavement condition presents a hazard to vehicular and pedestrian traffic.
- c. When curb and gutter, sidewalks, and utility structures have failed.
- d. When the striping and signage become unrecognizable or do not meet the current standards.
- e. When there is a change in use, or additions are being made.
- f. All pavements are to meet the minimum requirements of the Village of Vernon Hills Development Regulations, the IDOT Standard Specifications for Road and Bridge Construction, the International Property Maintenance Code, and the Illinois Accessibility Code, current editions.

3. *Enforcement:* After an inspection of the property deficiencies, a written notice of the deficiencies will be provided to the property owner for response.

4. *Submittal for Permit:*

a. *Plans*

(i) A copy of the original approved design plan should be used for reference, where practical. The plan submittals are to delineate the proposed improvements including repair strategy, extent of repairs or modifications, and location. Four copies of the repair plans are to be submitted for review and comments, including a cost estimate.

b. *Pavement*

(i) When pavement removal has been determined to be necessary (i.e.: severe alligating, potholes, etc.), the pavement is to be repaired in accordance to the Village Development Ordinance and the IDOT standard Specifications for Road and Bridge Construction, Section 440 Pavement Rehabilitation, or current editions. The pavement shall be neatly saw cut before removal. The asphalt is to be removed and replaced with the required pavement cross-section. Should the sub base be determined to be unstable, a proof roll may be required to determine the scope of repairs. If the sub base

is determined to be failing after the asphalt has been removed, then the appropriate repairs will be required.

(ii) All patching areas shall be re-graded and compacted. The sawcut asphalt edges shall require bituminous asphalt prime coat before asphalt is placed.

(iii) Asphalt mixtures shall meet the minimum Illinois Department of Transportation mixture requirements for HMA Binder and HMA Surface Course mixtures, current requirements. Minimum surface course overlays shall be 1½ inch in thickness. The use of Illinois Department of Transportation modified mixtures shall require the approval of the Village Engineer.

(iv) Asphalt overlays shall require a ½ inch, minimum, grind/milling of the entire existing asphalt pavement surface. Grind/milling shall provide a "friction" surface to properly receive the new asphalt surface overlay.

(v) Asphalt overlays within curb gutters shall not be allowed.

(vi) Asphalt milling shall be required along all Barrier type curb. The minimum height of the curb above the finished pavement surface shall be no less than four (4) inches, after the overlay.

(vii) A Butt Joint shall be required where existing asphalt meets new pavement surfaces. Butt Joints shall meet the Standard Specifications for Road and Bridge Construction, Illinois Department of Transportation, current edition.

(viii) Asphalt milled areas shall be mechanically swept before the placement of prime coat. Additional hand cleaning may be required to properly prepare the areas along the curb and gutter, sidewalks and utility structures. Prime Coat application shall be applied at the recommend application rates of the Standard Specifications for Road and Bridge Construction, Illinois Department of Transportation, current edition. The use of aggregate (sand) for prime is recommended for high traffic areas. For areas where the entire asphalt surface course has been milled prime coat shall be placed to allow sufficient cure time so that it will not be picked up under traffic.

(ix) All paving shall be placed in accordance with the Standard Specifications for Road and Bridge Construction, Illinois Department of Transportation, current edition, and the Village of Vernon Hills Code of Ordinances, Development Regulations, current edition.

(x) Concrete pavement areas to be replaced shall be patched in accordance to the Standard Specifications for Road and Bridge Construction, Illinois Department of Transportation, current edition, and Village of Vernon Hills Code of Ordinances Development Regulations, current edition. Pavement thickness shall be eight (8) inches minimum in thickness.

c. *Manhole Structures (storm, sanitary, water)*

(i) All structures in the paved areas shall be reconstructed as necessary to maintain planned drainage and integrity of the structure. All repairs are to conform to the current Village Standards No. 3, 4, 7, 9, and 16.

- (ii) Broken or deteriorated adjusting rings are to be replaced. Two (2) adjusting rings totaling eight (8) inches maximum is required.
- (iii) All broken castings and lids are to be replaced.
- (iv) Adjustments to any valve vaults, valve boxes, b-boxes, and sanitary manholes shall be done in accordance to the requirements of the Lake County Department of Public Works Department. Prior approvals shall be required.
- (v) Use of frame insets is permitted
- (vi) Structures and manhole lids are to be cleaned after paving.

d. Curb and Sidewalks

- (i) All failing, broken, non-draining and curbs that create a trip hazard curb and gutter shall be replaced.
- (ii) All failing, broken, non-draining and trip hazard sidewalks shall be replaced.
- (iii) Stalled or deteriorated sidewalk shall be replaced when it fails to meet the standards of the adopted edition of the International Property Maintenance Code.
- (iv) Curb and sidewalk is to be replaced in accordance to the current Village Standards No. 28, 28A, 29, and 30.

e. Lighting

- (i) Lighting is to be verified after reconstruction of the parking lot to assure that damage has not occurred.

f. Signage and Striping

- (i) Shall be updated to the current standards.
- (ii) The originally approved striping plans, including the exact amount of handicapped parking stalls will be used. Any changes to the plan must be approved by the Building Division.
- (iii) Handicap parking spaces and signs shall meet the requirements of the Illinois Accessibility Code and Village of Vernon Hills Code of Ordinances.
- (iv) All signs shall be legible and reflectivity shall conform to the current MUTCD manual requirements. Missing damaged or bent signs and posts shall be replaced or restored to meet the requirements of the Village of Vernon Hills Code of Ordinances.
- (v) All signposts are to conform to the current Village Standards No. 44 and 45 and will be plumb and securely embedded into the pavement.
- (vi) All sign panels missing, not legible or reflective are to be replaced to meet the current Village codes.

g. Grading within the Parking Lot (Islands)

- (i) All areas within the parking lot shall be graded to drain, and settled areas filled in.
- (ii) Any alterations to the existing parking lot islands are to be submitted for approval.

h. Traffic Control

(i) It is the responsibility of the permit applicant to provide advance warning and safe access to the adjacent businesses during construction.

(ii) Proper notification is to be provided prior to the start of construction.

(iii) The construction area will be properly barricaded, and any required informational signs shall be provide and maintained.

(iv) The storage of equipment and construction material will be confined to areas that are well lit and properly barricaded. At no time shall the area block drainage areas, fire hydrants, fire lanes, or entrance/exits.

**VILLAGE OF VERNON HILLS
EXHIBIT NO. 36**

PARKING AREA LAYOUT

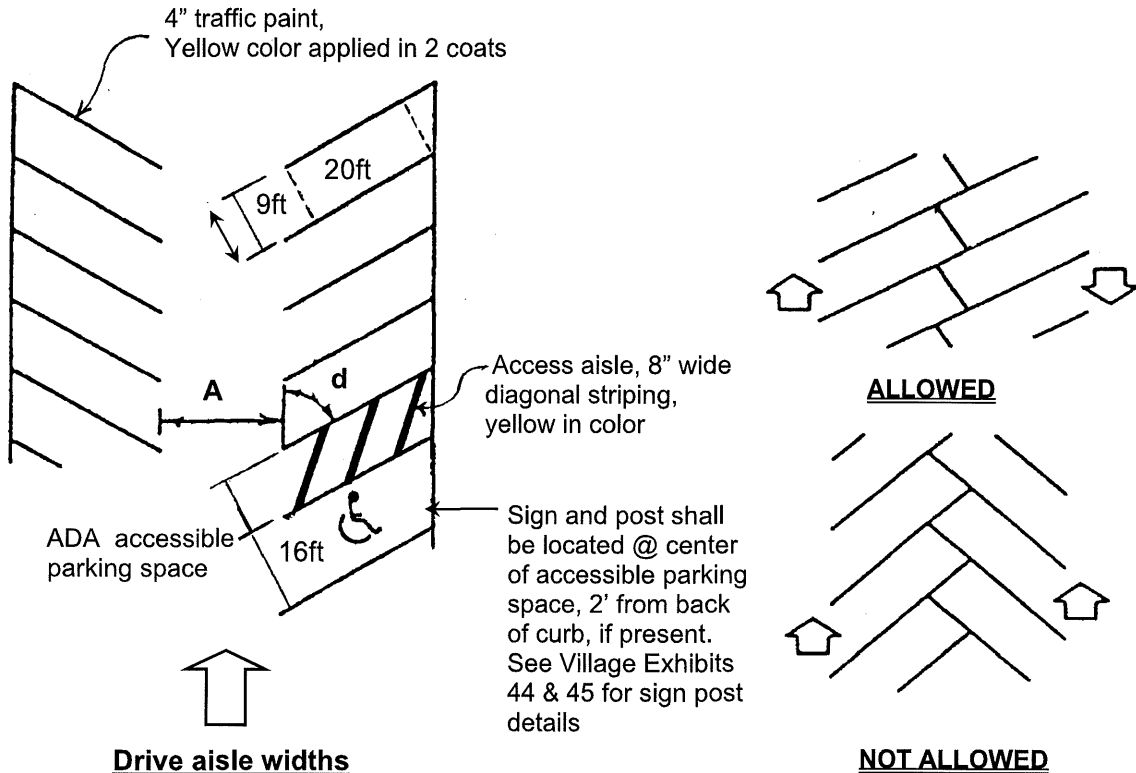

Drive aisle widths

<u>d</u>	<u>A</u>
45°	13'
60°	18'
90°	24'

Notes:

1. Each ADA accessible parking space shall consist of a 16' wide parking space including an 8' wide diagonally striped access aisle. Adjacent parking spaces shall not share a common access aisle.
2. All striping shall conform to the current ADAAG, State of Illinois Accessibility Code, and Village codes. A high quality yellow pavement marking paint shall be used, applied in 2 coats.
3. All accessible parking spaces shall be located on the shortest accessible route of travel from adjacent parking to an accessible entrance.
4. Accessible parking spaces and access aisles shall be level with surface slopes not exceeding 2% (1:50) in all directions.
5. All two-way aisles shall be 24' wide.
6. Parking space length shall not be less than that shown above. No deduction shall be made for perimeter parking space overhang distance.
7. Parking provisions of the zoning ordinance shall take precedence over provisions illustrated here if they are more restrictive.

Section 400, Illustration B, Figures 9-10

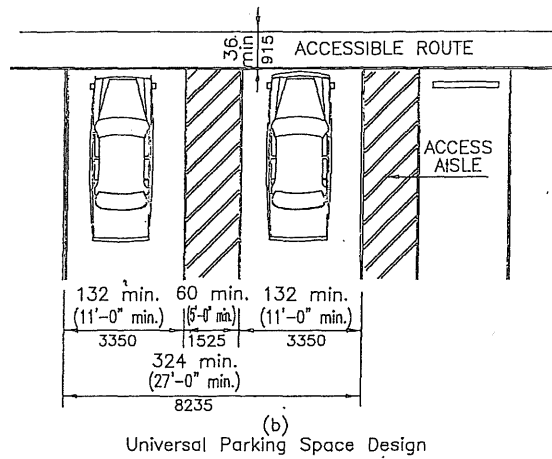
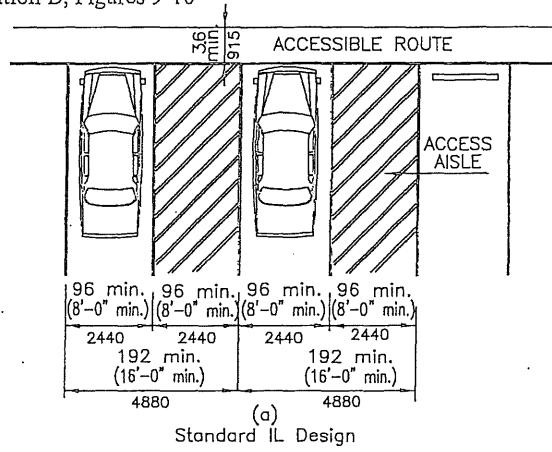

Fig. 9
Dimensions Of Parking Spaces
(Typical Parking Spaces for 45°, 60°, and 90° Arrangements)

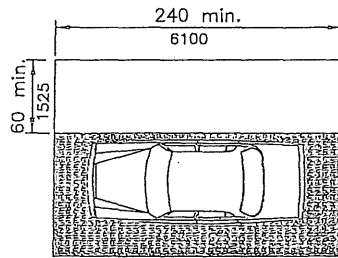
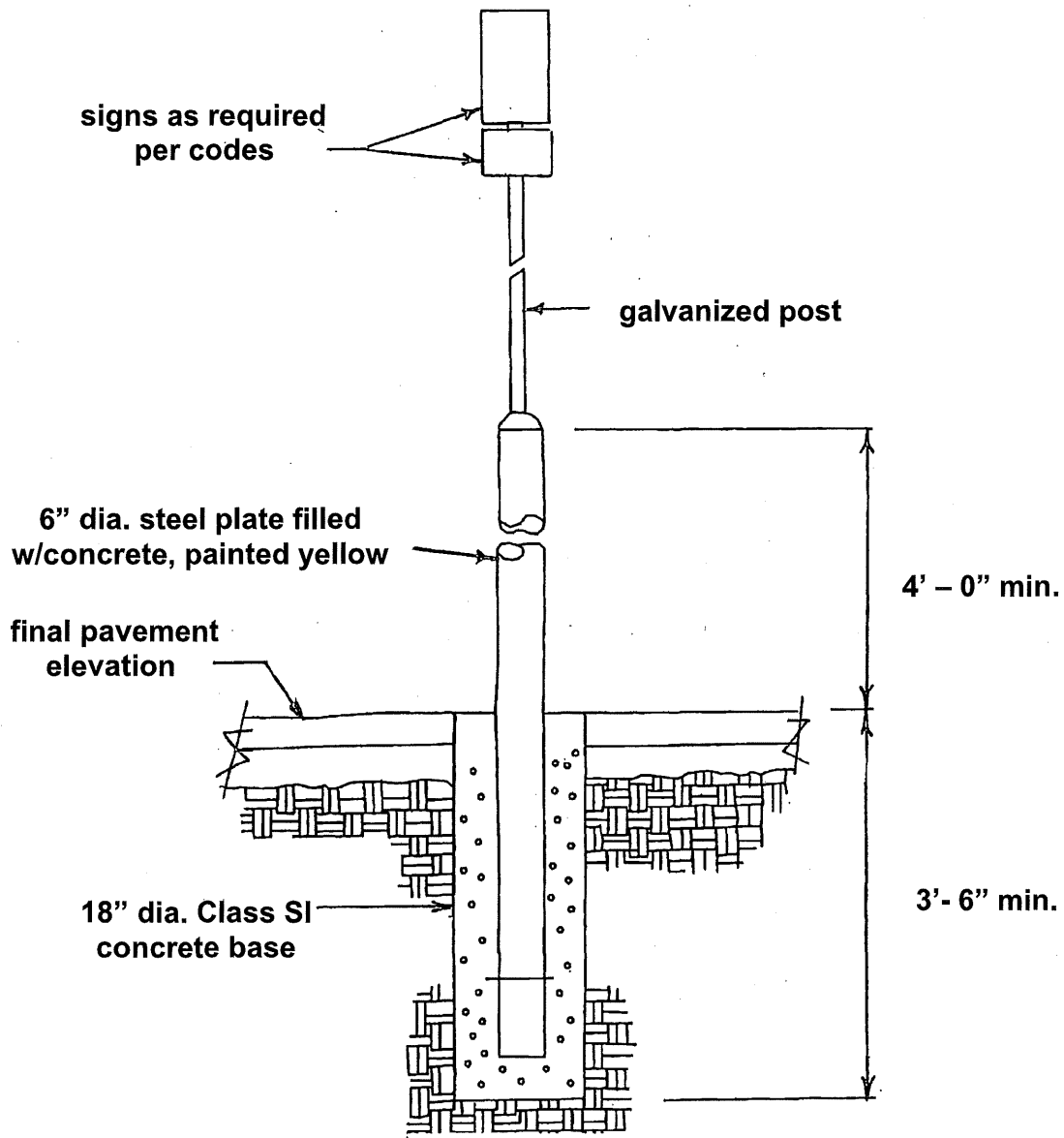

Fig. 10
Access Aisle at Passenger Loading Zones

VILLAGE OF VERNON HILLS
EXHIBIT NO. 44

SIGN POSTS LOCATED WITHIN PAVEMENT



NOTES:

1. All other sign posts not within pavement shall be placed at a minimum of 2' from the back of curb, but not more than 5' from the back of curb.
2. Minimum mounting height for handicap parking signs is 4' from bottom of sign to finish grade. All other signs shall be 7' from bottom of sign to finish grade.

VILLAGE OF VERNON HILLS
EXHIBIT NO. 45

SURFACE MOUNTED SIGN POST BASE

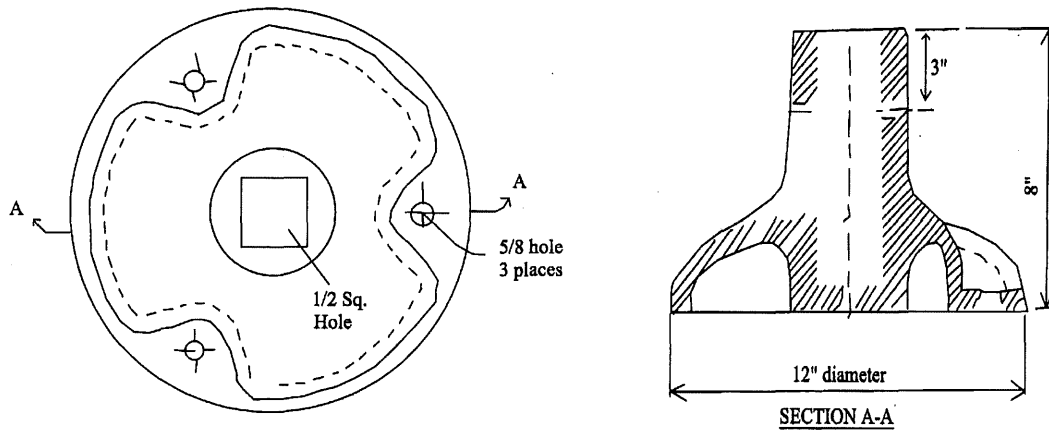

PLAN

SECTION A-A

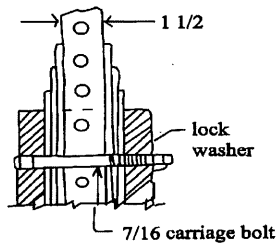

POST ASSEMBLY DETAIL

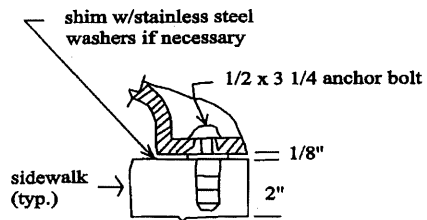

**ANCHOR BOLT
DETAIL**

TYPICAL APPLICATION FOR SIGNS MOUNTED ON SIDEWALKS

Notes:

1. For signs and posts located within pavement, refer to Exhibit No. 44.
2. Signs and posts not within pavement shall be set 2.5' behind back of curb.
3. Minimum mounting height for sign panels is 7' from bottom of sign panel to finished grade.
4. Minimum mounting height for Handicap Parking signs is 4' from bottom of R7-8 sign panel to finished grade.
5. A galvanized metal sign post is recommended to prevent rust.

Section 400.ILLUSTRATION C "Parking Sign"

HANDICAPPED PARKING SIGN

Effective January 1, 1985, Public Act 83-1316 amended Sec. 11-301 of "The Illinois Vehicle Code" to require Handicapped Parking Signs (for parking lots subject to "The Illinois Vehicle Code") to comply with R 7-8 sign shown below (U.S. Department of Transportation Standard). Existing signs may remain, but their useful lives shall not be extended by other means than normal maintenance.

Note: This is a standard sign and may be ordered from any traffic sign supplier by number. The arrow should be omitted where there is only one space. The arrow may also be made to point in only one direction. The arrow may also be replaced by "time" such as 9 AM - 5 PM where a part time restriction exists. The sign must be supplemented with the Illinois Standard R7-1101 plate giving the amount of the fine for illegally parking in the reserved space(s).

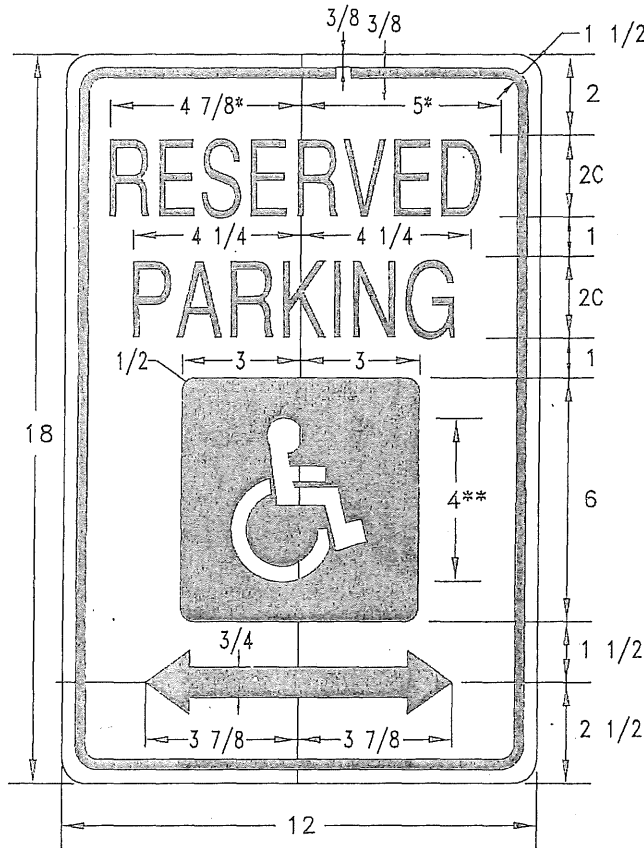

R7-8

DIMENSIONS (INCHES)

COLORS

LEGEND AND BORDER—PANTONE 340C

WHITE SYMBOL ON PANATONE 286 BACKGROUND

BACKGROUND—WHITE

* REDUCE SPACING 80%

156

Rev. 12/95

Section 400.ILLUSTRATION D "S 250 Fine" Sign

Reproduced with permission from the American National Standards Institute.

ILLINOIS STANDARD R7-I101

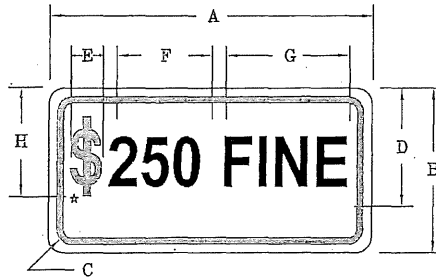

COLOR: LEGEND AND BORDER GREEN NON-REFLECTORIZED
(PANTONE 340C)

BACKGROUND WHITE REFLECTORIZED

SIGN SIZE	DIMENSIONS							
	A	B	C	D	E	F	G	H
12 x 6	12.0	6.0	1.5	4.5	1.19	3.53	4.6	4.0

SIGN SIZE	SERIES LINES	MAR-GIN	BOR-DER	BLK STD.
	1			
12 x 6	3A	0.37	0.37	B5-126

All Dimensions in Inches
To be used with R7-8
*\$=Series 3A "s"

Where a fine in excess of \$100 is established by an Municipality By Ordinance in accordance with the statutes, the actual amount of the fine should be shown.

This plate may be mounted directly below the R7-8 sign or combined with that sign on a single 12-inch by 24-inch panel.

Note: For a fine of \$200, use F=4.0 and G=4.0 (reduce letter to letter spacing as necessary to fit).

Figure 3B-22. International Symbol of Accessibility Parking Space Marking

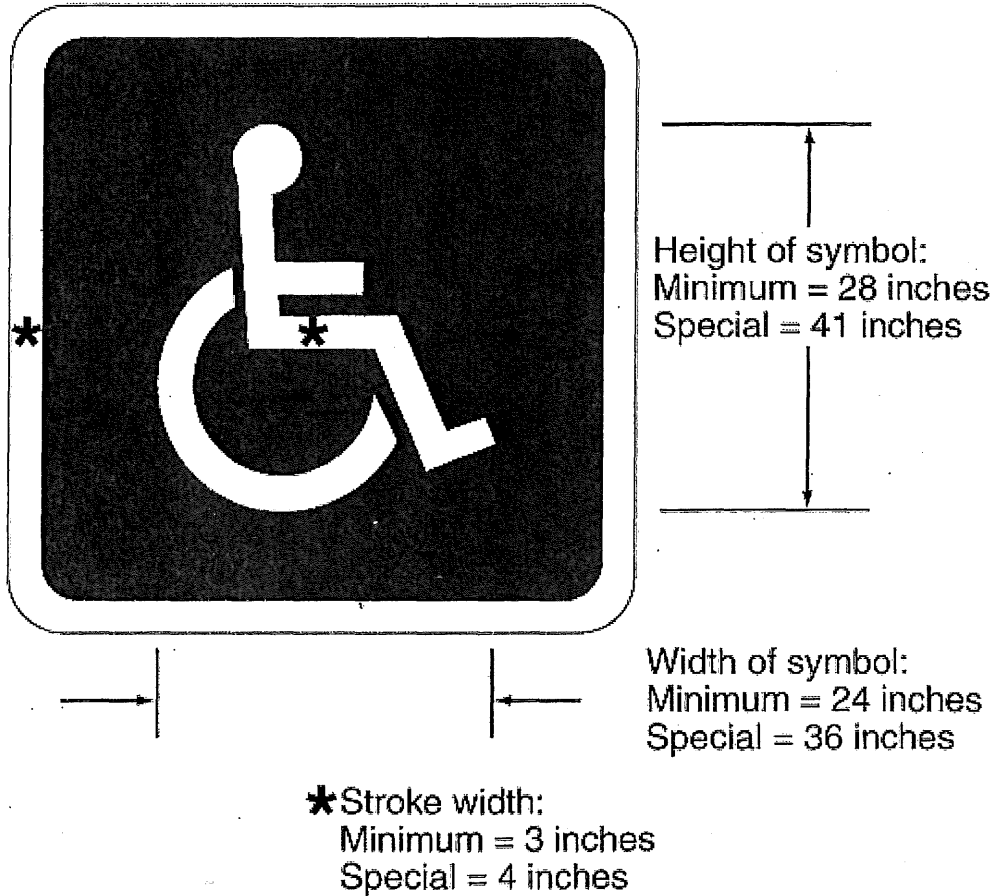

Note: Blue background and white border are optional

This figure shows the International Symbol of Accessibility parking space marking. The figure shows a blue square with rounded corners and with a white border, also with rounded corners. The blue background and white border are noted as optional. Centered within the blue square is a white symbol of a person sitting in a wheelchair.

The height of the wheelchair symbol is shown as a minimum of 28 inches and a special height of 41 inches.

The width of the symbol is shown as a minimum of 24 inches and a special width of 36 inches.

The stroke width of the white border and wheelchair symbol is shown as a minimum of 3 inches and a special width of 4 inches.

ORDINANCE NO. 2018-030

**AN ORDINANCE AMENDING THE CODE OF ORDINANCES
OF THE VILLAGE OF VERNON HILLS, CHAPTER 5,
ARTICLE IV, PROHIBITING THE USE OF COAL TAR**

WHEREAS, the President and Board of Trustees of the Village of Vernon Hills is authorized to prescribe minimum standards for the purpose of promoting the public health, safety, convenience and general welfare for the people of Vernon Hills; and

WHEREAS, numerous natural assets exist within the Village, including ponds, streams and wet lands which enhance the Village's environmental, recreational and cultural resources, and contribute to the health and welfare of the community; and

WHEREAS, recent research into the environmental impact of coal tar derived pavement sealants with the objective of improving storm water management and to address water pollution, found that: (i) driveway sealants are wide spread pollutants of water and major health threats; (ii) homeowners and businesses can easily use similar sealant products without coal tar; and (iii) many municipalities and states have banned the use of coal tar; and

WHEREAS, the President and Board of Trustees having reviewed this matter at its Committee of the Whole meeting on September 7, 2017; determined that prohibiting the use of coal tar sealants on public and private property within the Village and to prohibit the sale of coal tar sealants by businesses located within the Village is necessary to promote the health and welfare of the community.

**NOW, THEREFORE, BE IT ORDAINED BY THE PRESIDENT AND BOARD OF TRUSTEES
OF THE VILLAGE OF VERNON HILLS, COUNTY OF LAKE AND STATE OF ILLINOIS:**

SECTION I. That Chapter 5, Article IV, Section 5-80, "Pavement Sealants" of the Vernon Hills Code of Ordinances is hereby created and approved to read as follows:

Section 5-80 Pavement Sealants

(a) Introduction/Purpose.

It is the intent and purpose of this Section to provide regulations that protect the natural assets within the Village, including ponds, streams and wet lands, and which enhance the Village's environmental, recreational and cultural resources, and contribute to the health and welfare of the community.

(b) Applicability

This Ordinance shall apply to the use of coal tar sealants on public and private property within the Village, and to the sale of coal tar sealants by businesses located within the Village.

(c) Definitions.

1. Coal Tar Products: means pavement sealant or sealcoat products that contain coal tar, coal tar pitch, coal tar derivatives, coal tar pitch volatiles, coal tar mixtures or any variation assigned the Chemical Abstracts Service (CAS) numbers 65996-93-2, 65996-89-6, or 8007-45-2.
2. Pavement Sealing: means the application of sealant or sealcoat products to maintain any surface, including but not limited to: a street, driveway, driveway approach, drive aisle, on

or off-street parking area, sidewalk, bike trail, patio, sports facility, loading area or facility, roadway or similar paved surface.

3. Person: means any individual, partnership, firm or corporation.

(d) Sale of Coal Tar Products Prohibited

No person shall sell, offer or display for sale within the Village, at wholesale or at retail, Coal Tar Products of any kind.

(e) Use of Coal Tar Products Prohibited

On public or private property, no Coal Tar Products of any kind shall be applied or used on the surface of any street, driveway, driveway approach, drive aisle, on or off-street parking area, sidewalk, bike trail, patio, sports facility, loading area or facility, roadway or similar paved surface within the Village.

(f) Penalty

Any person found violating any terms of this Chapter shall be found guilty of a misdemeanor and shall, upon conviction thereof, be fined in an amount not less than that described in the Village Code of Ordinances, Chapter twenty five (25), Comprehensive Fees and Penalties.

SECTION II. SEVERABILITY. In the event that any section, clause, provision, or part of this ordinance shall be found and determined to be invalid by a court of competent jurisdiction, all valid parts that are severable from the invalid parts shall remain in full force and effect. If any part of this ordinance is found to be invalid in any one or more of its several applications, all valid applications that are severable from the invalid applications shall remain in effect.

SECTION III. REPEAL AND SAVINGS CLAUSE. All ordinances or parts of ordinances in conflict herewith are hereby repealed; provided, however, that nothing herein contained shall affect any rights, actions or causes of action which shall have accrued to the Village of Vernon Hills prior to the effective date of this ordinance.

SECTION IV. EFFECTIVE DATE. This ordinance shall be in full force and effect from and after its passage, approval and publication as provided by law.

SECTION V. ORDINANCE NUMBER. This ordinance shall be known as Ordinance Number 2018-030

Adopted by roll call vote as follows:

AYES: 4 – Marquardt, Oppenheim, Takaoka, Koch

NAYS: 0 - None

ABSENT AND NOT VOTING: 2 – Hebda, Schultz



Roger L. Byrne, Village President

PASSED: 2/20/2018

APPROVED: 2/20/2018

PUBLISHED IN PAMPHLET FORM: 2/21/2018



John Kalmar, Village Clerk

